

Research Journal of Pharmaceutical, Biological and Chemical Sciences

“Gerteis®” An Advanced Technology of Roller Compaction System in Roll Compaction/Dry-Granulation, From Gerteis®.

Saikh Mahammed Athar Alli*

Department of Pharmaceutical Sciences, Faculty of Health Sciences, Shiats (Deemed to be University), Allahabad-221 007, Uttar Pradesh, India.

ABSTRACT

Presented work is attempting for focusing application and technical aspect of “Gerteis®” an advanced roller compaction system in dry-granulation process. Roller compaction is consensus as important agglomeration process and a principal step in dry granulation. It attributing for tendency of introducing lean, economical, and continuous manufacturing process to reduce expenses of research & development and manufacturing. Pharmaceutical and allied industries are not abstention in said race. Attempting objective, an advanced roller compaction system developed by Gerteis®, a Swiss manufacturer. This system patented as “Gerteis®” is capable in measuring and controlling all product quality relevant parameter, on-line. It basing on floating roller compaction method allowing for successful dry granulation of wider range of formulations. Its application is growing in pharmaceutical and allied industry, and awareness among professionals seems poor. This attributable to scarce literatures describing associated technology and use. In this regard, present work attempting for focusing. Presented information be having wider application and will be a helping hand for professionals.

Keywords: Dry-granulation, Gerteis®, advanced, roller compaction, system.

**Corresponding author*

INTRODUCTION

Roller compaction is of increasing important agglomeration technique in producing granules, a principal step in dry granulation [1]. It attributed most from tendency for introducing lean manufacturing to reduce expenses of research & development and manufacturing. Pharmaceutical and allied industry has general trend and practice of introducing lean, economical, and continuous process. With this objective Gerteis[®], a Swiss manufacturer, developed and patented roller compaction systems, 'Gerteis[®]' [2-7].

Gerteis[®], the advanced roller compaction system, is capable in measuring and controlling all product quality relevant parameters, on-line. This compaction system employs floating type roller allowing for successful dry granulation of wider range of formulations comparing conventional roller compactor [2-7].

Gerteis[®] system based dry-granulators registered as Pactor[®] and Polygran[®]. These machines are capable in calibrating and validating all the parameters. Besides, they are delivering a well-controlled and documented manufacturing process. To cope inter batch variations; said machines are fitted with control systems to allow equal granule properties during manufacturing, according to 'process analytical tool' [2-7].

However, rare literatures are merely describing technological aspect and usefulness of advanced roller compaction system in 'Gerteis[®]'. In setting of above, associated technical matters had being focusing with present work. Presented information has applicability in processing of dry granulation process and will be a helping hand for researchers.

Process Basics

Granulation or agglomeration is operations forcing primary powder particles to adhere and form larger, multiparticle, entities called granules (or agglomerates). Said process increases bulk density and yields granules with larger size and more isodiametric size distribution that enables a better control of content uniformity and avoids demixing or segregation. Furthermore, granulation leads to reduction in dusting, enhancing wettability and flowability [1, 8-10].

Definition of granulation is evolving through the years. Latest, 'is a size enlargement process that converts fine or coarse particles (primary powder particles) into physically stronger and larger agglomerates (multiparticle entities), called granules, with wished physico-chemical properties/characteristics' [8-10].

Basing upon the type of processing, involved, granulation process/technology is conventional and novel/advanced. Dry-granulation and wet-granulation are conventional. Novel/advanced granulation methods are extrusion-spheronization, foam binder, freeze, fluidized bed, Gerteis[®], melt/thermoplastic, spray drying, steam, thermal adhesion, pneumatic dry granulation, moisture activated dry granulation, and so on [8-10].

Wet-granulation is performing by adding a liquid solution (with or without binder) to powders, to form a wet mass or by adding the powder together with an adhesive, instead by

compaction. While dry-granulation does not require heat, and solution and solvent. Advancement in conventional method had been evolving due to technological advancements is being attributed to novel methods. Advancement being attributed from the methodology of addition and or distribution of binder fluid, kneading/massing and or handling of wet mass, for growth of granule, and so on [8-10].

Dry-granulation is the preferred granulation process, inherited to its pros not being limited to simplicity and low cost. It is suitable for product that may be sensitive to moisture and heat or for materials that do not compress well after wet-granulation. Dry-agglomeration of powders leading to compacted mass is achievable by applying a force onto the powder bed without aid of heat and solvent. The process of compaction in general causes a considerable size enlargement and thus yielded compacted mass called briquettes, flakes or ribbons. Subsequent to compaction process, a milling step is following to obtain the desired granules [1, 8-10].

There are two main processes of dry granulation, 'slugging' and 'roller compaction'. Process of slugging involves pre-compression of powder blend into large tablet (called 'slug') in a heavy-duty tablet press. Roller compaction involves pre-compression or squeezing the continuous stream of powder blend between two pressure rollers. This produces a sheet of material (called 'flake'). In both cases, intermediate products (tablet/slug or sheet/flake) are broken (by suitable milling) to granular material. Then desired size fraction separated out, by sieving. The unused fraction may be reworking to minimise waste [1, 8-10].

Amongst slugging and roller compaction, slugging resulting granulates whose properties cannot be controlled well either. Roller compaction being considered to advantageous inherited to its pros and preferred, is becoming an important agglomeration technology [11].

The compaction behaviour of powders during roller compaction is influenced by several factors, as following [12-16].

- Process conditions related factors like roll speed, roll gap, mechanisms and speed of feeding, throughput, and roll-surface texture;
- Nip angle and pressure. Difference in serration volume of rolls changes nip angle that significantly affects ribbon thickness or porosity. Roll sets having serration volume, approximately twice, result 20-25% thicker ribbons; [13]
- Vacuum de-aeration: application of vacuum decreases normal stress with subsequent increase in gap and ribbon thickness; [14] and
- Factors relating powder properties like particle size, shape, moisture content, and so on.

All of these factors contribute to ribbon porosity of the compacted mass. Ribbon porosity inversely related to ribbon thickness. Relative level of ribbon compaction is prerequisite for ribbons with equivalent in-gap porosities [12]. In-gap ribbon porosity contributes to optimization of the downstream granule processability. Parameters of the granulator, set in downstream line, contribute to granule properties. Important contributing

parameters of oscillating-granulator are rotor speed, oscillating angle, aperture of mesh screen and rotor type [12, 15, 16].

Consensus is that to have reproducible granule properties following parameters requiring understanding and monitoring in roller compaction/dry granulation process [11, 12].

- Roller mill parameter: throughput, speed ratio in both first and second stages, gap between roll pair (in both stage), and shape, size and surface texture of the rolls;
- Nip pressure and nip angle; and
- Granulator parameter: speed and type of rotor, oscillating angle, and aperture of mesh screen.

Roller compaction can be achievable with either floating/variable-gap rollers or fixed-gap rollers. Maintaining analogous normal stress applied by the rolls on ribbon for a given gap between fixed-gap rollers, is troublesome. Consequently this contributing to large fluctuations in the ribbon and granulate properties, as in slugging. While, floating type minimises fluctuations in the properties of ribbon and granulates. In addition, level of de-aeration is contributing to narrated fluctuations [13, 14, 17].

During scale up and in bench to pilot and manufacturing scale maintenance of reproducible ribbon porosity and subsequently granule properties, of milled material, at each scale is a challenging task. It has importance with both floating/variable-gap rollers and fixed-gap rollers [13, 17].

Precise control and maintenance of discussed parameters, in reproducible way, is prerequisite to reproduce properties of granules, in floating-roller based compaction process. Gerteis[®] compaction system developed to combat said and allied technical issues [13-17].

Gerteis[®]

Gerteis[®] is an advanced technology of dry granulation process. It comprises a roller compaction system and a gentle milling (granulation) system. Inline existences of these two unit-operations minimize generation of too many fines. This technology is capable in measuring and controlling all product quality relevant parameters, on-line. Gerteis[®] technology based compactors can additionally be adapted with a pneumatic system, to rework excess fines [2-7, 18].

Unique features of Gerteis[®] Roller Compaction system

Unique features of Gerteis[®] Roller Compaction system as follows [2-7].

- It built in consistent feed system with torque control of screw feeder and tamp auger. This ensures precision dosing of powder to rollers.

- Contains angled compaction rollers with free-floating gap design and in process force control. These features allowing feed consistency, constant ribbon density and minimise temperature gain.
- Larger diameter of rollers provides a longer dwell time in the nip area.
- Superior punch and die roller design to provide a constant density over the ribbon width. Compaction system employs interchangeable press roller with different surface like knurled, smooth, toothed or custom design. These features virtually eliminate fines minimizing need for their recirculation or reworking.
- Three stage milling process with the granulating oscillating mill and with the adjustable screen clearance. Granulator is open star rotor, closed pocket type integrated with bulk-breaking and pre-crushing features for optimal results. Features to produce a consistent and controllable particle size distribution.
- Inbuilt perfect sealing system reduces dusting of fines.
- High containment solution achieves standard containment performance level is of $3 \mu\text{g}/\text{m}^3$.

Gerteis® Roller Compaction system based roller compactors from Gerteis®

The flagship of Gerteis® had designed and engineered the roller compactor. The compactor deigns comprises of two major classes, Pactor® and Polygran®, and each class has ranges of model. Pactor® range comprises Mini-Pactor®, Macro-Pactor® and Ultra-Pactor® while Polygran® range comprises Polygran®, Mini-Polygran®, and Mini-Polygran® Plus. Model ranges are for satisfying needs of development, pilot projects, and up to full-scale production batches (Table-1) [2-7].

Pactor® and Polygran® comprise generally a feeding system, a compaction unit and a size reduction unit (Figure-1). All of these range has inbuilt unique features of Gerteis® roller compaction system. However, their model ranges differs by several options or features, add-on or optional (Table-1). The add-on or optional options and or features are for assuring to receive the optimal solution for needs of dry granulation, case-to-case basis [2-7].

Table 1: Important options and features of Pactor® and Polygran® model ranges.

Options and Features	Mini-Pactor® [2]	Macro-Pactor® [3]	Ultra-Pactor® [4]	Polygran® [5]	Mini-Polygran® [6]	Mini-Polygran® Plus [7]
Fully instrumentation option	Available	Available	---	----	---	----
Full machine calibration	Available	Available	---	Available	---	----
Occupational exposure limit level	$3 \mu\text{g}/\text{m}^3$	$3 \mu\text{g}/\text{m}^3$	$0.1 \mu\text{g}/\text{m}^3$	---	----	$5 \mu\text{g}/\text{m}^3$
Gap between rollers (in mm)	1 – 6	1 – 6	2 – 6	2 – 5	1 – 4	1 – 4
Press force (in N/cm)	1 – 20	1 – 20	1 – 20	1 – 15	1 – 15	1 – 15
Roller speed (in rpm)	1 – 30	1 – 30	1 – 30	2 – 15	0.5 – 5	0.5 – 5
Throughput (in kg to kg/h)	0.1 to 400	0.1 to 400	0.1 to 400	0.5 to 300	10 to 20	10 to 40
Suitable for						
Research and Development	Yes	Yes	Yes	Yes	Yes	Yes
Bench and small-scale	Yes	Yes	Yes	Yes	Yes	Yes
Development and pilot scale	Yes	Yes	Yes	Yes	No	No
Mobile frame	No	No	No	No	Yes	Yes
Quick and fast maintenance	No	No	No	Yes	Yes	Yes
Inter-batch changeover	No	No	No	Yes	Yes	Yes
Gross weight (in kg)	1200	1700	2500	1200	400	500

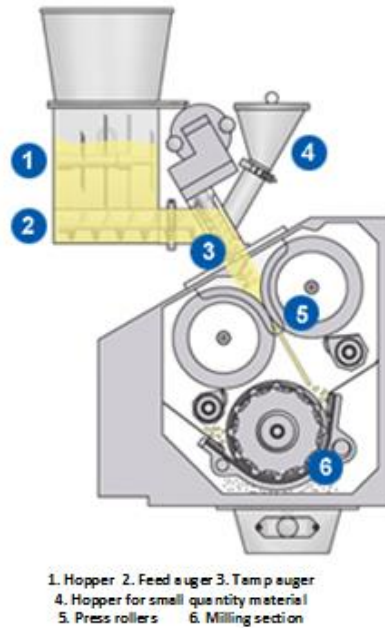

Figure 1: Basic design of roller compactors from Gerteis®

Polygran® - setup attributes smart engineered parts assembly contributes to effortless machine maintenance. In addition, maintenance and changeover from batch to batch can be completing in simple, quick and fast way. Changeover from scale-up to production volumes can equally be achievable instantly and hassle-free [5-7].

Important options and features are follows [2-7].

- Full instrumentation is with critical quality process parameter and data-acquisition.
- Full machine is calibration.
- Vacuum de-aeration.
- Press-roller cooling/heating.
- Separate feed system for feeding materials of small quantity.
- Operator interface for industrial PC solution.
- Ranges of occupational exposure limit options. Design level of $< 3 \mu\text{g}/\text{m}^3$, $< 1 \mu\text{g}/\text{m}^3$, and $< 0.1 \mu\text{g}/\text{m}^3$.
- Multiple cleaning options like Manual, Wash-in-Place, and Clean-in-Place. Easy and fast dismantling of components allows manual cleaning. Wash-in-Place option is for removing air borne dust during dismantling which reduces time of cleaning cycle. Clean-in-Place option is for completely automated cleaning without dismantling. This feature eliminates contact of operator with potent and hazardous products.
- Integrated air-handling system, guarantees the containment safety, optional.
- Integrated nitrogen adding and oxygen monitoring is available (optional).

Advantages of Gerteis® roller compactors over conventional

Gerteis® roller compaction system have several advantages over conventional, as follows [2-7].

- No temperature issue, heating up of material during whole process is only 2-4 °C.
- Roller cooling option, add-on features enhances applicability. Feature suitable for material having melting point < 30 °C.
- Consistent material feeding system achieves product with consistent characteristics and quality.
- Unique combinations of inclined roller arrangement, movable press roller with rims and gap control minimizes amount of the un-compacted fines.
- Unique milling system generates granules having optimal particle size distribution with minimum amount of fines. Thus recycling systems only needed in rare case.
- Have improved containment safety.
- Ultra high containment options are available. Said option avoids contamination of manufacturing areas and personal by high potent actives.
- Ranges of occupational exposure limit options with multiple cleaning options are available.
- Highly energy efficient as requires no air conditioning, and low running costs.
- Integrated air handling system and integrated nitrogen adding and oxygen monitoring option is available.
- Reproducible results are accomplishable. Real data calibration and calibration of the whole system is doable.

CONCLUSION

Awareness among professionals relating usefulness and associated technology of 'Gerteis®' will revolutionise dry-granulation process. Besides, on-line monitoring and controlling all product quality relevant parameter and complete automation will improve efficiency and applicability. Efforts will be allowing for dry-granulating wider range of formulations with compliance of regulations. Future will proclaim application by presenting enormous product in field of pharmaceutical, food and chemical.

REFERENCES

1. Kleinebudde P. Eur J Pharm Biopharm 2004; 58(2): 317-326.
2. Product brochure- Mini-Pactor®. Available from: http://www.gerteis.com/_files/data/Gerteis_Mini_Pactor_Web_en.pdf. Accessed 02 March 2014.
3. Product brochure- Macro-Pactor®. Available from: http://www.gerteis.com/_files/data/Gerteis_Marco_Pactor_Web_en.pdf. Accessed 02 March 2014.
4. Product brochure- Ultra-Pactor®. Available from: http://www.gerteis.com/_files/data/Gerteis_Ultra_Pactor_Web_en.pdf. Accessed 02 March 2014.
5. Product brochure- Polygran®. Available from: http://www.gerteis.com/_files/data/Gerteis_Polygran_Web_en.pdf). Accessed 02 March 2014.
6. Product brochure- Mini-Polygran®. Available from: http://www.gerteis.com/_files/data/Gerteis_Mini_Polygran_Web_en.pdf). Accessed 02 March 2014.

7. Product brochure- Mini-Polygran®-Plus. Available from:
http://www.s3process.co.uk/sites/default/files/product_brochures/MINI-POLYGRAN-PLUS-Laboratory-R-D-Roller-Compactor.pdf. Accessed 02 March 2014.
8. Agrawal R, Yadav N. Int J Pharm Frontier Res 2011; 1(1): 65-83.
9. Solanki HK, Basuri T, Thakkar JH, Patel CA. Int J Pharm Sci Rev Res 2010; 5(3): 48-54.
10. Saikh MAA. Int J Pharm Sci Res 2013; 4(1): 55-67.
11. Gamble JF, Tobyn M, Dennis AB, Shah T. Pharm Dev Technol 2009. [Epub ahead of print]
12. Gamble JF, Tobyn M, Dennis AB, Shah T. Pharm Dev Technol 2010; 15(3): 223-229.
13. Daugherty PD, Chu JH. Pharm Dev Technol 2007; 12(6): 603-608.
14. Nesarikar VV, Vatsaraj N, Patel C, Early W, Pandey P, Sprockel O, Gao Z, Jerzewski R, Miller R, Levin M. Int J Pharm 2012; 426(1-2): 116-131.
15. Sakwanichol J, Puttipatkhachorn S, Ingenerf G, Kleinebudde P. Pharm Dev Technol 2012; 17(1): 30-39.
16. Wu CY, Hung WL, Miguélez-Morán AM, Gururajan B, Seville JP. Int J Pharm 2010; 391(1-2): 90-97.
17. Nesarikar VV, Patel C, Early W, Vatsaraj N, Sprockel O, Jerzewski R. Int J Pharm 2012; 436(1-2): 486-507.
18. Rathod H, Khinchi MP, Agrawal D, Gupta MK. Int J Pharm Res Dev 2012; 4(04): 021-030.